

**MATERIAL LIST:**

- A. SERVICE CLAMP REQUIRED.
- B. 1 1/2" CORPORATION STOP (TYPICAL) - SERVICE PIPE OUTLET. (SEE NOTE #2)
- C. 1 1/2" SERVICE PURPLE POLY PIPE (TYPICAL).
- D. BRANCH CONNECTION: 1 1/2" OR 2" SERVICE PIPE INLET AND 2 3/4" MALE I.P.T. OUTLETS 7 1/2" O.C. (SEE NOTE #2)
- E. 3/4" LOCKING ANGLE METER STOP; FEMALE I.P.T. INLET AND SWIVEL COUPLING NUT OUTLET.
- F. PLASTIC RECTANGULAR METER BOX. (SEE TABLE BELOW)
- G. PIPE CASING WHERE APPLICABLE. (AS PER DETAIL WT-01)
- H. WATER METERS, CENTERED IN BOX WITH PURPLE BONNETS.
- I. WATER METER COUPLING; MALE I.P.T. X SWIVEL COUPLING NUT.
- J. BRONZE GATE VALVE: NON-RISING STEM (3/4" OR 1") FEMALE I.P.T. (PROPERTY OWNERS CUT-OFF OUTSIDE METER BOX IN SEPARATE VALVE CAN WITH LID AS PER CITY OF ROUND ROCK STANDARDS).
- K. 3/4" OR 1" PIPE MEETING CITY OF ROUND ROCK PLUMBING CODE REQUIREMENTS.

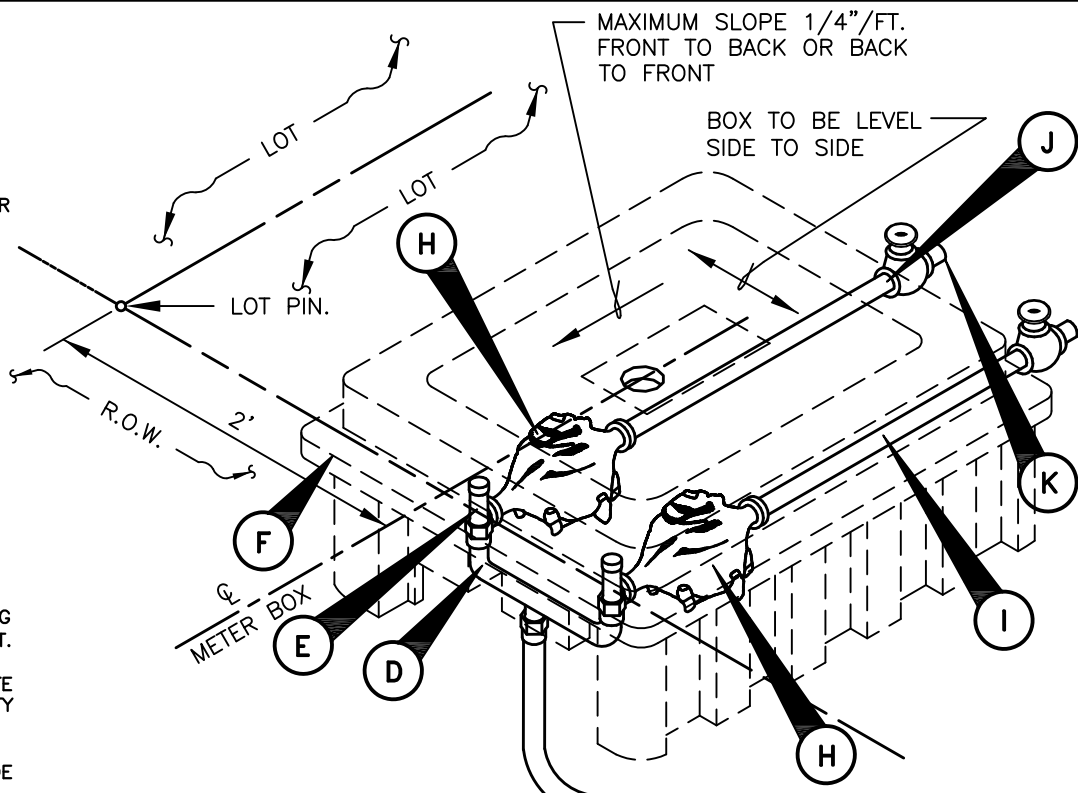

**NOTES:**

1. SERVICE PIPE SHALL BE COPPER TUBE SIZE. IT MAY BE 150 P.S.I. ANNEALED SEAMLESS TYPE "K" COPPER TUBING OR 200 P.S.I. BLACK COLORED POLYETHYLENE HAVING A DIMENSION RATIO OF 9 (DR9).
2. ALL STAINLESS STEEL INSERTS THAT COME WITH COMPRESSION FITTINGS SHALL NOT BE USED ON ANY CONNECTIONS.
3. SERVICE SADDLES SHALL BE WRAPPED COMPLETELY WITH 8 MIL. PURPLE POLYETHYLENE FILM.
4. TOP OF BOXES SHALL BE 1" ABOVE FINISHED GRADE.
5. PIPING AND TUBING SHALL BE INSTALLED IN ACCORDANCE WITH SECTION 510.3 OF THE STANDARD SPECIFICATIONS. SPECIAL ATTENTION IS CALLED TO "PIPE BEDDING ENVELOPE" AND "BACKFILLING", SECTIONS 510.3 (14) AND 510.3 (25), RESPECTIVELY.
6. AXIS OF METER ASSEMBLY (LINE THROUGH METER STOP, METER, PIPING AND OWNERS CUTOFF) SHALL BE 10" BELOW TOP OF BOX.
7. SLOTS PROVIDED IN METER BOX TO ACCOMMODATE PIPING INTO AND OUT OF BOX, SHALL NOT BE MODIFIED.
8. BRANCH CONNECTION AND BOTH ANGLE METER STOPS MUST BE INSTALLED PRIOR TO FIRST METER INSTALLATION EVEN THOUGH THE SECOND PROPERTY MAY NOT BE READY FOR SERVICE.
9. LOCATION OF METER BOXES SHALL BE SUBJECT TO THE APPROVAL OF THE C.O.R.R.
10. VALVE BOX TO BE FACTORY COLORED. FIELD PAINTING IS NOT ACCEPTABLE.

PART NUMBER	SERIES	COLOR	HEIGHT	WIDTH	LENGTH
DFW38C-14-BODY*	38C	PURPLE	14"	TOP = 20-1/2"	TOP = 21-1/2"
DFW38C-AF1EQA-LID*	38C	PURPLE	2"	LID = 17"	LID = 18"
DFW38C-14-AF1EQA*	38C	PURPLE	14"	BASE = 17"	BASE = 21-1/2"

\* MANUFACTURED BY DFW PLASTICS INCORPORATED OR APPROVED EQUAL.

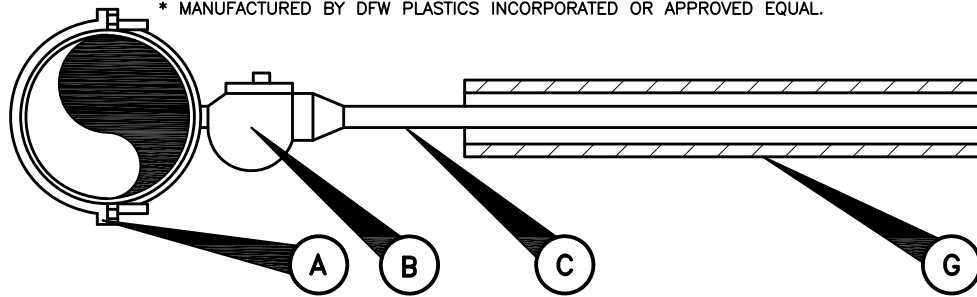

METER SIZE	LENGTH
5/8"	7 1/2"
3/4"	7 1/2"
1"	11"

RECORD SIGNED COPY  
ON FILE AT U&ES DEPARTMENT  
APPROVED

03-01-18  
DATE

THE ARCHITECT/ENGINEER ASSUMES  
RESPONSIBILITY FOR THE APPROPRIATE  
USE OF THIS DETAIL. (NOT TO SCALE)

**CITY OF ROUND ROCK**

**DUAL 5/8", 3/4" OR 1"  
REUSE WATER METERS DETAIL**

DRAWING NO:  
RW-03

