

MATERIAL LIST:

- A. SERVICE SADDLE REQUIRED. SERVICE SADDLE TO BE EPOXY COATED WITH DUAL STAINLESS STEEL BANDS.
- B. 1 1/2" OR 2" CORPORATION STOP - SERVICE PIPE OUTLET. (SEE NOTE #2)
- C. 1 1/2" OR 2" SERVICE PIPE.
- D. LOCKING ANGLE METER STOP; SERVICE PIPE INLET X SWIVEL COUPLING NUT OUTLET:
 - FOR 1 1/2" METERS: 1 1/2" X 1 1/2"
 - FOR 2" METERS: 2" X 2"
 - SEE NOTE #2
- E. PLASTIC RECTANGULAR METER BOX. (SEE TABLE BELOW)
- F. PIPE CASING WHERE APPLICABLE. (AS PER DETAIL WT-01)
- G. WATER METER, CENTERED IN BOX. (SEE TABLE BELOW)
- H. WATER METER COUPLING; MALE I.P.T. X SWIVEL COUPLING NUT:
 - LENGTH OF PIPE TO BE DETERMINED BY CONTRACTOR.
 - EXTEND PIPE TO 4"-6" OUTSIDE OF METER BOX.
- I. BRONZE GATE VALVE: NON-RISING STEM (1 1/2" OR 2") FEMALE I.P.T. (PROPERTY OWNERS CUT-OFF OUTSIDE METER BOX IN SEPARATE VALVE CAN WITH LID AS PER CITY OF ROUND ROCK STANDARDS).
- J. BUSHING (IF NECESSARY) AND PIPE MEETING CITY OF ROUND ROCK PLUMBING CODE REQUIREMENTS.

MAXIMUM SLOPE 1/4"/FT. FRONT TO BACK OR BACK TO FRONT

BOX TO BE LEVEL SIDE TO SIDE

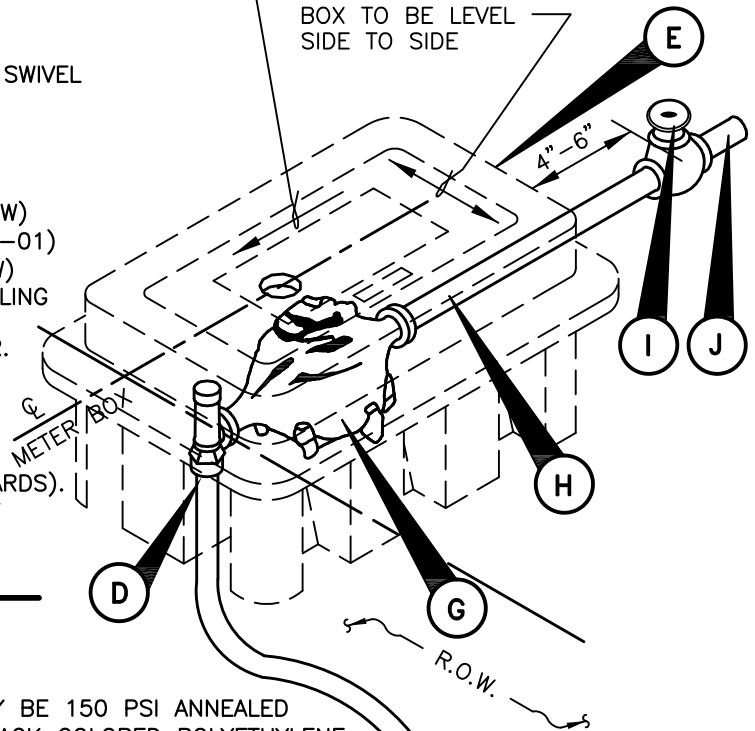

NOTES:

1. SERVICE PIPE SHALL BE COPPER TUBE SIZE. IT MAY BE 150 PSI ANNEALED SEAMLESS TYPE "K" COPPER TUBING OR 200 PSI BLACK COLORED POLYETHYLENE HAVING A DIMENSION RATIO OF 9 (DR9).
2. ALL STAINLESS STEEL INSERTS THAT COME WITH COMPRESSION FITTINGS SHALL NOT BE USED ON ANY CONNECTIONS.
3. SERVICE SADDLES SHALL BE WRAPPED COMPLETELY WITH 8 MIL. POLYETHYLENE FILM.
4. TOP OF BOXES SHALL BE 1" ABOVE FINISHED GRADE.
5. PIPING AND TUBING SHALL BE INSTALLED IN ACCORDANCE WITH SECTION 510.3 OF THE STANDARD SPECIFICATIONS. SPECIAL ATTENTION IS CALLED TO "PIPE BEDDING ENVELOPE" AND "BACKFILLING", SECTIONS 510.3 (14) AND 510.3 (25), RESPECTIVELY.
6. AXIS OF METER ASSEMBLY (LINE THROUGH METER STOP, METER, PIPING AND OWNERS CUTOFF) SHALL BE 10" BELOW TOP OF BOX.
7. SLOTS PROVIDED IN METER BOX TO ACCOMMODATE PIPING INTO AND OUT OF BOX, SHALL NOT BE MODIFIED.
8. LOCATION OF METER BOXES SHALL BE SUBJECT TO THE APPROVAL OF THE C.O.R.R.

PART NUMBER	SERIES	COLOR	HEIGHT	WIDTH	LENGTH
DFW65C-14-BODY*	65C	BLACK	14"	TOP = 18-3/4"	TOP = 30-3/8"
DFW65C-AF1EQA-LID*	65C	BLACK	1-7/8"	LID = 15-1/4"	LID = 26-7/8"
DFW65C-14-AF1EQA*	65C	BLACK	14"	BASE = 15-1/4"	BASE = 30-3/8"

* MANUFACTURED BY DFW PLASTICS INCORPORATED OR APPROVED EQUAL.

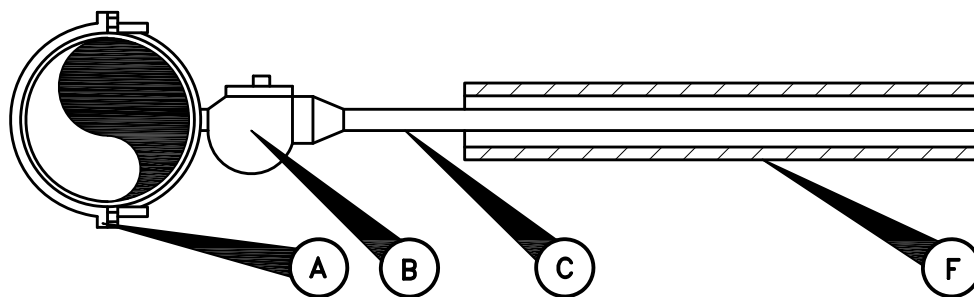

METER SIZE	LENGTH
1-1/2"	13"
2"	17"

RECORD SIGNED COPY
ON FILE AT U&ES DEPARTMENT

APPROVED

03-01-18
DATE

THE ARCHITECT/ENGINEER ASSUMES
RESPONSIBILITY FOR THE APPROPRIATE
USE OF THIS DETAIL. (NOT TO SCALE)

CITY OF ROUND ROCK

DRAWING NO:
WT-03

**SINGLE 1-1/2" OR 2"
WATER METER DETAIL**

