

**COVER PLAN VIEW**

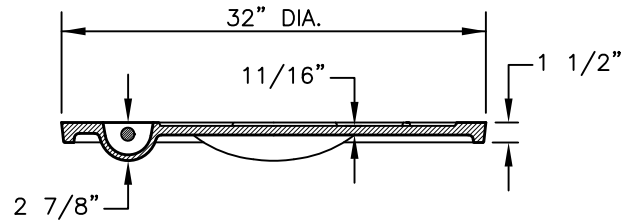

**COVER SECTION VIEW**

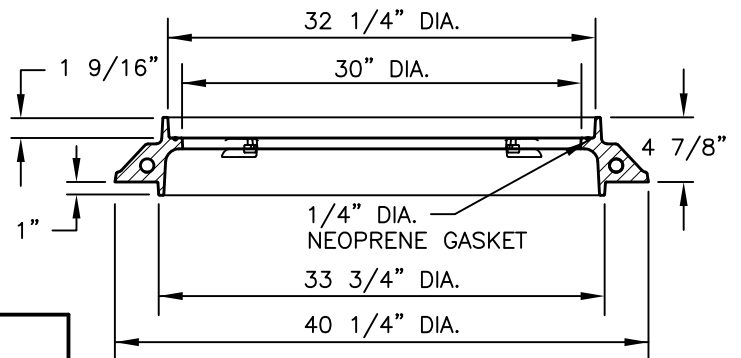

**FRAME SECTION VIEW**

NUMBER	NOTE
1	1 1/2" LETTERING (STYLE: BOOKMAN OLD STYLE)
2	1" LETTERING (STYLE: BOOKMAN OLD STYLE)
3	1/2" FLAT FACE GOTHIC LETTERS
4	3/8" FLAT FACE GOTHIC LETTER

**NOTES:**

- COVER AND FRAME SHALL COMPLY WITH STANDARD SPECIFICATIONS FOR DRAINAGE, SEWER, UTILITY AND RELATED CASTINGS: AASHTO DESIGNATION M306-04.
- MANHOLE COVER AND FRAME ASSEMBLY SHALL BE MODEL NUMBER: V-2432 (PRODUCT NUMBER: 42432074), AS MANUFACTURED BY EAST JORDAN IRON WORKS, INCORPORATED, OR APPROVED EQUAL.
- ALL CORNERS AND EDGES SHALL HAVE A 1/16" MINIMUM AND 1/8" MAXIMUM RADIUS.
- MANHOLE COVERS SHALL BE CAST WITH TWO 1" DIAMETER STEEL PICKBARS.
- MANHOLE COVER WEIGHT SHALL BE 175 LBS. FOR DUCTILE IRON. WEIGHT SHALL BE CAST ON BOTH TOP AND BOTTOM OF COVER.
- MANUFACTURER SHALL CERTIFY THAT EACH MANHOLE COVER MEETS HS-20 LOADING.
- FILLETS SHALL BE 1/4" RADIUS UNLESS OTHERWISE SPECIFIED.
- MANUFACTURER SHALL REMOVE EXCESS IRON AND MACHINE FINISH SEATING SURFACES TO NOTED DIMENSIONS.
- COVER SHALL BE DIPPED IN A WATER-BASED ASPHALTIC COATING, PRIOR TO SHIPMENT FROM FOUNDRY.
- BOLTS SHALL BE 5/8"-11NC X 2" LONG HEX STAINLESS STEEL WITH WASHER.
- MANUFACTURER SHALL DRILL 2-3/16" X 1/2" DEEP HOLES FOR A MANHOLE NUMBER PLATE TO BE PROVIDED BY THE CITY OF ROUND ROCK. THE TOP HOLE SHALL BE DRILLED 1" O.C. FROM THE BOTTOM OF THE PICKBAR AND THE BOTTOM HOLE SHALL BE DRILLED 4" O.C. FROM THE TOP HOLE.

RECORD SIGNED COPY  
ON FILE AT U&ES DEPARTMENT

APPROVED

03-01-18

DATE

THE ARCHITECT/ENGINEER ASSUMES  
RESPONSIBILITY FOR THE APPROPRIATE  
USE OF THIS DETAIL. (NOT TO SCALE)

**CITY OF ROUND ROCK**

DRAWING NO:  
WT-28

**BOLTED WATER MANHOLE  
COVER AND FRAME DETAIL**

